

A floppy cycling cap with its little bill is an icon of cycling. With style, it protects us from the burn of the sun on our scalps and (when worn backwards) our necks, the sting of sweat and rain and sunbeams in our eyes, and in the case of the warmer cycling caps, the chill of wind and winter. A cycling cap with a lightweight build is not only breathable, but easily stowable, either under the helmet or in a jersey pocket. And the bill is perfect for cocking askew, up, or backward — to block the elements or invite a podium kiss.

DESCRIPTION:

This sewing pattern includes instructions to create a traditional four-panel cap in any size, with the option of accent ribbon and/or a warm earflap. It features an average sized (2" deep) hard or soft bill, a twill tape sweatband, and elastic in the back panel for easy fit.

RECOMMENDED FABRICS:

- Nonstretch, woven light- to mid-weights fabrics such as cotton twill, canvas, poplin, denim, corduroy. Also, tropical weight wool, wool flannel and wool garbadine.
- Fabric requirements: ¼ yard (36" width and wider)

NOTIONS:

- ½ yard braided ½" elastic
- Bill interfacing. A plastic school folder, a quart-sized yogurt container, or a firm interfacing like Pellon 70 works well, too.
- ¾ yard of ¾" twill tape
- Thread



Original pattern and instructions © Caroline Paquette 2009-2020 - Little Package. This pattern is for personal home use. Caps are not to be produced for commercial purposes from this pattern, nor are they to be made into items for sale. This pattern is copyright protected and reproduction of it is not permitted.

Caroline Paquette

Little Package Cycling Caps

Portland, Oregon USA

cap@little-package.com

<https://www.little-package.com>

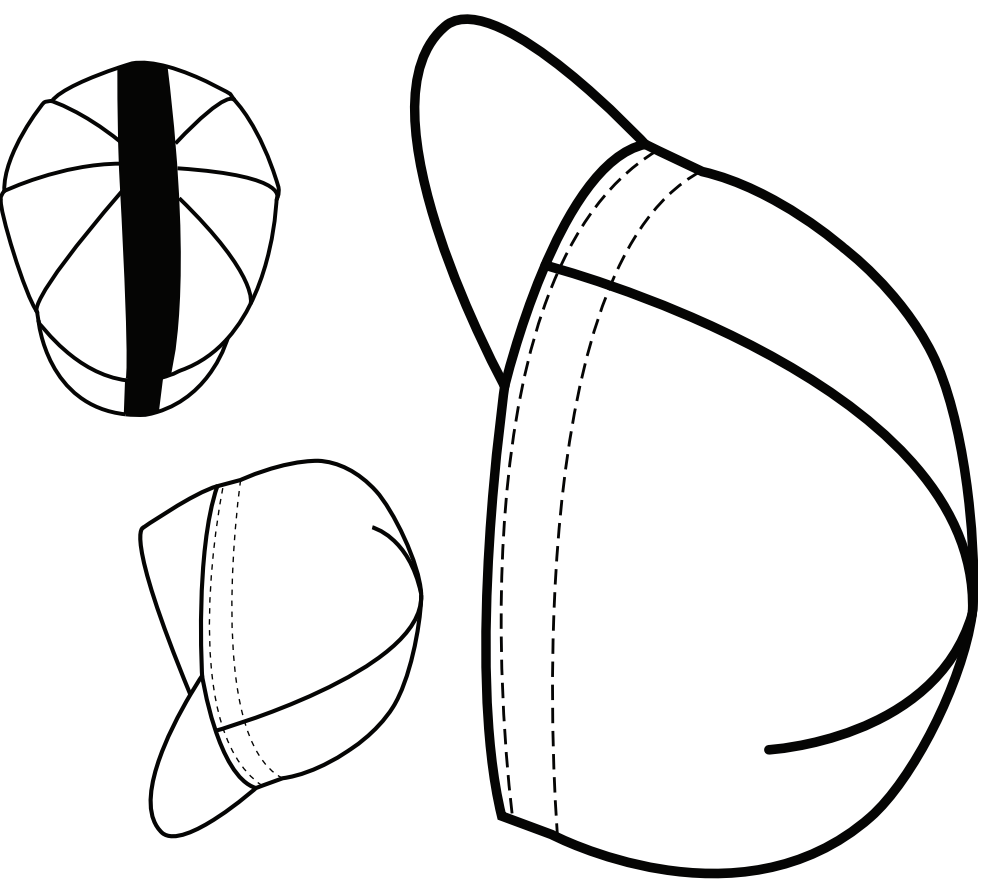

**FOUR-PANEL CYCLING CAP - #01 - ALL SIZES
INTERMEDIATE DIFFICULTY**

LITTLE PACKAGE

Thank you for your purchase of a sewing pattern kit from Little Package Cycling Caps! If you have a rudimentary knowledge of sewing, either by hand or with machine, you can put together a cycling cap on your own. Take your time — read through and conceptualize the instructions before beginning. Don't be discouraged if your first cap isn't picture perfect. It takes practice. That said, I'm happy to help. Feel free to email me with any questions.

Caroline Paquette
Little Package Cycling Caps
Portland, Oregon USA
cap@little-package.com
<https://www.little-package.com>

If you need more inspiration, you can look through photographs of Little Package caps here: <http://flic.kr/s/aHs1KvYe>

SIZING:

Included is a template for a one-size-fits-most cap. 9-10cm of elastic will make a one size fits most cap. Use a little more or less to make a comfortable cap.

	BABY (1yr)	KID (5yr)	SM	ONE SIZE	LG
Head size:	46-49cm	50-54cm	54-56cm	56-59cm	59-63cm
Photocopy at:	89%	93%	97%	100%	103%
Elastic length:	7cm	7cm	8cm	9-10cm	10-11cm

To adjust this pattern to fit another size head, photocopy all pattern pieces at the percentage indicated in the table, and try the recommended elastic length. Adjust as desired.

NOTES:

INSTRUCTIONS:

- Seam allowance is $\frac{1}{4}$ " unless otherwise stated.
- Right side of fabric is shown in grey.
- Have fun!

1. Fold each of four crown pieces in half along dotted line, right sides together.

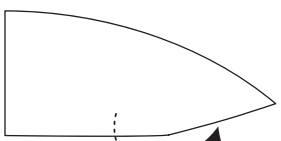

Sew "V" shaped edges together from the pointy tips (large dot) down towards the crook of the V (now folded on itself). To shape the crown nicely, "swoop" the seam line so the obtuse angle is rounded. Repeat with three other crown pieces.

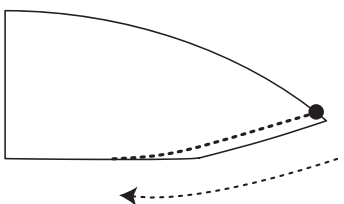

2. Open up the four panels. Place two panels right sides together, and sew together along one rounded edge, starting at large dot. Repeat with two remaining crown panels. You now have two crown halves.

Iron the two halves, pressing the seams all in one direction (to the left if viewed from the inside).

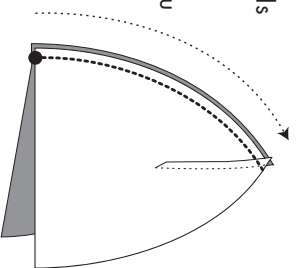

3. Sew the crown halves, right sides together, along the rounded edge, starting at large dot. Match seams at the crown apex so that when the crown is turned right side out you have a pretty star pattern at the apex. This isn't so important if you are going to be sewing a ribbon over the apex - it won't show! In fact, if you want ribbon on the crown, now is the time to do it. If you also want ribbon on the bill, now is the time to sew ribbon on one or both of the bill pieces. Press.

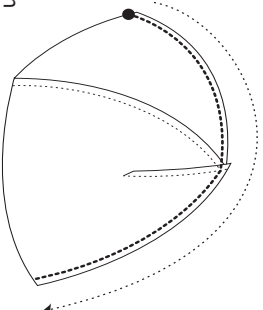

4. Put the two bill pieces right sides together and sew along the rounded edge. Clip small pie-shaped notches approximately $\frac{3}{4}$ " apart along the rounded edge, close to but careful not to clip the seam. This makes it easier to turn the bill fabric right side out, and reduces bulk.

Turn right side out and insert bill stiffener. Center the stiffener and pull the raw edges so that the fabric around the stiffener is as taut as possible. Pin in. Baste along pins. Remove pins.

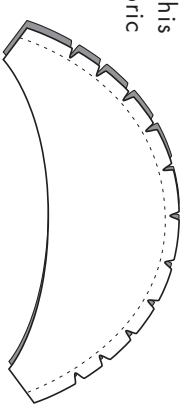

The bill will have a variable seam allowance depending on how tightly the fabric is pulled. There may be a large, rough seam allowance when you are done basting. Trim to $\frac{3}{8}$ - $\frac{1}{2}$ " from basting to make step 5 easier.

If using a firm *fiber* interfacing bill insert, you will want to top-stitch the bill to keep the interfacing from moving around and folding inside the bill. Top-stitching also adds stiffness and promotes a nice round shape when worn. You can get creative with top-stitching, or just sew in rows like Little Package. To see photos of some top-stitched bills, visit this URL: <http://www.flickr.com/photos/littlepackage/tags/softbill/>

5. Mark the center of one crown panel (the front panel) at raw edge with a pin or chalk. Match the center of the bill (marked with a small notch) with the center front of the crown, the right side of the crown and the top of the bill face to face. Pin in place such that the basted line of stitching from step 4 goes along an imaginary line on the crown about $\frac{3}{8}$ - $\frac{1}{2}$ " from the rough edge. If you have clipped the raw edges of the bill to $\frac{3}{8}$ - $\frac{1}{2}$ ", then you can line up the raw edge of the crown with the raw edges of the bill. Baste bill to crown close to previous line of basting, starting at large dot. *

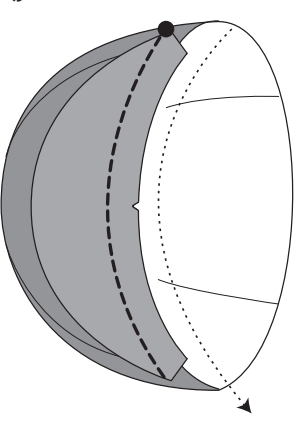

6. Starting at the center back (large dot), sew twill tape to right side (outside) of cap to create a casing. The seam should be about $\frac{3}{8}$ - $\frac{1}{2}$ " from the rough edge, and very close to the edge of the twill tape (about $\frac{1}{16}$ "). (The twill tape is shown as an uncolored band in the illustration.) When you get to where you've pinned the bill to the front of the cap, things get tricky. Make sure the crown and the bill lay flat as you pass them through your machine, that the front panel fabric is pulled clear of your needle. Try to place the twill tape's edge over the basted seam from step 4 and "trace" that line with

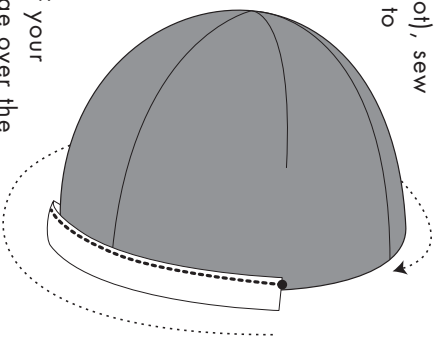

the new line of stitching through tape, bill and crown. You are attaching the bill to the cap by stitching the twill tape on. When you come full circle to where you started sewing on the twill tape, cut the tape $\frac{1}{2}$ - $\frac{3}{4}$ " longer than needed to make a complete circle, fold under edge, and finish (at the star) by sewing a short perpendicular line of stitches along the folded edge.

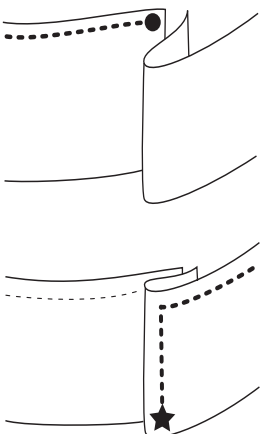

7. Cut a piece of elastic. The length depends on what size cap you are making, how loose or tight you want your cap to fit, and what type of elastic you use. Try pinning the elastic in place, one end at each marked star. Wear the cap and decide if it feels tight or loose. When decided, bar tack the elastic into the seams where back and side panels meet, about $\frac{1}{8}$ " away from the seam created in step 6. It can be tacked to the crown panel fabric or to the twill tape, both ways work. But avoid tacking over the seam from step 6!

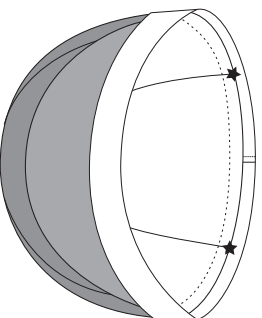

8. Fold the twill tape casing inside. On the outside, sew a line $\frac{5}{8}$ " from bottom edge of cap to seal the casing closed. Start the seam at the back left crown seam (large circle) and work around from there. This line of stitching shows so decide if you want the thread to match. Make sure to catch the twill tape with the stitching. It's more tricky closing the casing around the elastic! It helps to stretch the elastic out, pull everything into shape, and hold it stretched while sewing. This is probably one of the most difficult steps, but at the same time - hooray! You're done!

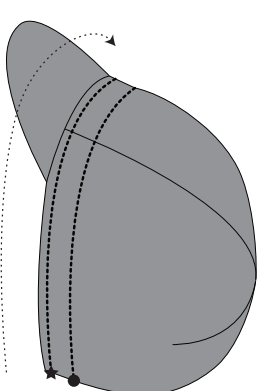

As an option, a second round of top-stitching from the back/left seam about $\frac{1}{8}$ " from edge (marked with a star), and all the way around to the right/back seam will decrease bulk, increase durability, and make the cap look more traditional.

FOOTNOTES:

* (refer to step 5) If you wish to try to make a warm winter hat with "earflaps" to cover your ears, here is where you add it in. Here are some hints...

Make sure your earflap fabric is knit, stretchy, not too bulky, and resumes its shape well after stretched - wool knits, cotton knits, and micro-fleece all work well. Cut a piece of the knit fabric the shape of a football 14.5-16.5" long (depending on head size) and 8" wide. Fold this piece of fabric in half lengthwise (like a hot dog bun), wrong sides together. Baste together along the curved edge to keep them together during the next step. Pin the center of the raw, curved edge to the center back of the hat, right sides together. Give the earflap a stretch and pin the raw edge near one point to the raw edge of the cap crown near the bill (Overlap the flap right over the bill up to one inch). Do the same for the other side. Stretch the earflap piece evenly onto the sides of the crown and pin down. Continue with step 6.



SEWING PATTERNS
FOUR-PANEL CYCLING CAP
DIGITAL VERSION - PDF - #01

For one-size cap
**Print at
100%**
Do not scale!

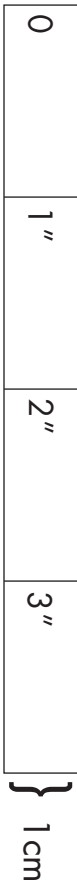

TIP: If this 4" x 1cm gauge matches a ruler, you have printed the pattern out at 100%

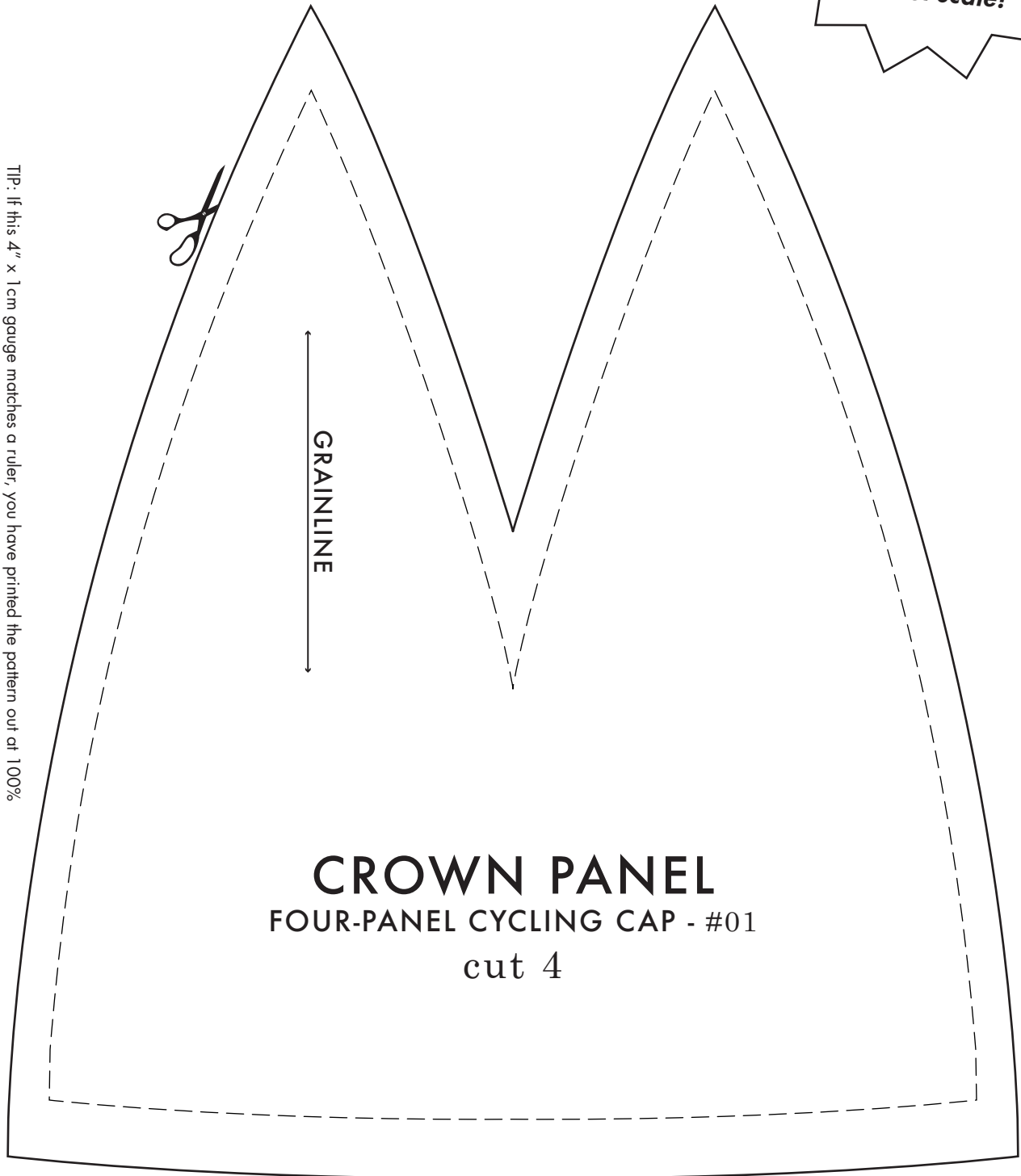

CROWN PANEL
FOUR-PANEL CYCLING CAP - #01
cut 4



SEWING PATTERNS
 FOUR-PANEL CYCLING CAP
 DIGITAL VERSION - PDF - #01

For one-size cap
Print at
100%
Do not scale!

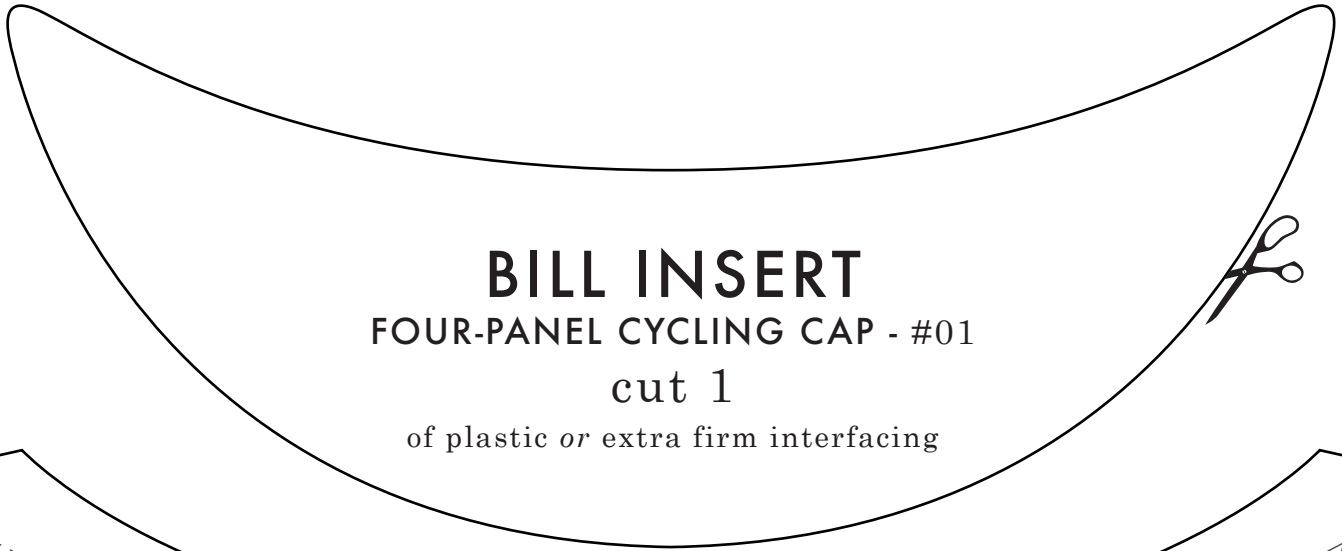

BILL INSERT
 FOUR-PANEL CYCLING CAP - #01
 cut 1
 of plastic *or* extra firm interfacing

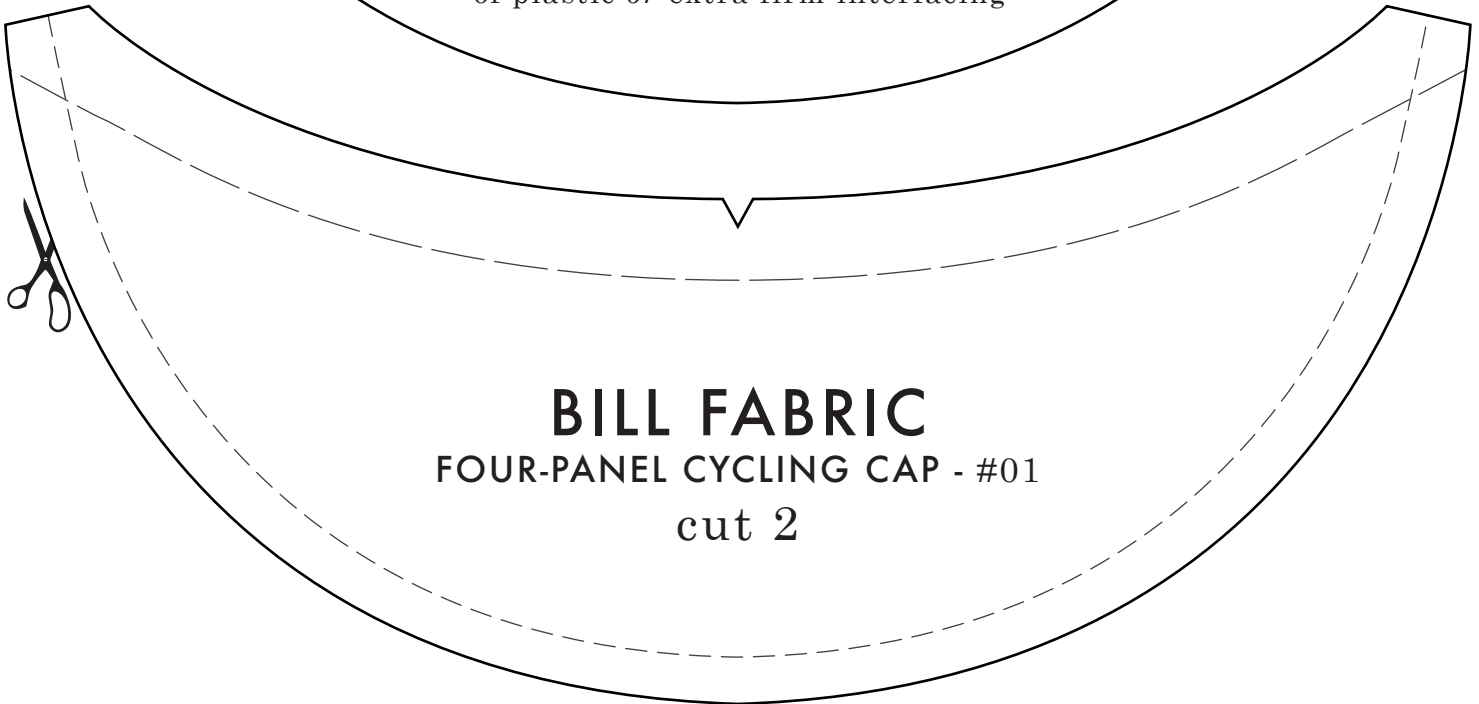

BILL FABRIC
 FOUR-PANEL CYCLING CAP - #01
 cut 2

TIP: If this 4" x 1cm gauge matches a ruler, you have printed the pattern out at 100%

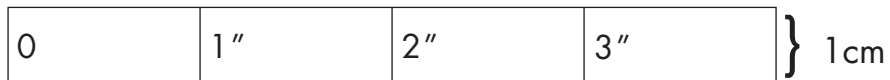

**Print at
100%**
Do not scale!

EARFLAP

3- or 4-PANEL CYCLING CAP - #01, #02

cut 1 on fold
of stretch knit fabric

small

medium

large

TIP: If this 4" x 1cm gauge matches a ruler, you have printed the pattern out at 100%

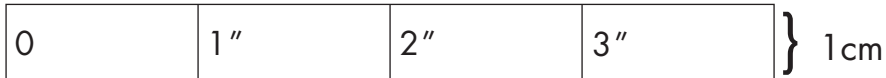

Cut 1 on fold/grainline